



3000 Series

Economy Indicators



T31P Indicator
shown with optional bracket



T31XW Indicator

Designed with affordability in mind, but with no compromise in performance!

The OHAUS 3000 series of economy indicators is ideal for general weighing and simple counting applications in production, packaging, warehouse, inventory, shipping and receiving areas. Ideal for bench and floor scale applications, the 3000 series offers either a dry-use, ABS plastic indicator housing or an IP66/NEMA4X water resistant stainless steel housing. Both indicators feature large, bright backlit displays, raised tactile keys and easy configurability. The 3000 series is the solution to your weighing applications that require dependability within an affordable budget.

Standard Features Include:

- T31P features a high-impact durable ABS housing with reversible rear cover for either wall, column or table-top mounting
- T31XW features an IP66/NEMA4X water resistant stainless steel housing with integral faceplate supports for easy servicing
- Large, backlit LCD display quickly displays results in a choice of multiple weighing units (lb, oz, combined lb:oz, kg or g)
- Drives up to four 350 Ω load cells
- 10,000d maximum displayed weighing resolution
- Parts counting mode with a minimum Average Piece Weight of 1d, selectable sample sizes, and automatic retention of last sample size used and Average Piece Weight data
- Built-in bidirectional RS232C for printing or connection to PC
- T31P includes an AC adapter and an internal rechargeable lead acid battery that lasts 100 hours between recharges
- T31XW has an internal universal switching power supply

3000 Series Economy Indicators

Specifications

Indicator	T31P	T31XW
Capacity Range	5 to 20000 kg or lb	
Maximum Displayed Resolution	1:10,000	
Minimum APW	1d	
Weighing Units	kg, lb, g, oz, lb:oz	
Functions	Weighing, Parts Counting	
Housing	ABS	Stainless steel
Display	1 in./2.5 cm digit height, 6-digit, 7-segment 1.5 in./3.8 cm high x 4.9 in./12.5 cm wide backlit LCD	
Backlight	White LED	
Keypad	4-button mechanical switches	4-button membrane switch
Ingress Protection	---	IP66 / NEMA 4x
Load Cell Excitation Voltage	5V DC	
Load Cell Drive	Up to four 350Ω load cells	
Load Cell Input Sensitivity	Up to 3 mV/V	
Stabilization Time	Within 2 seconds	
Auto-zero Tracking	Off, 0.5, 1 or 3 d	
Zeroing Range	2% or 100% of capacity	
Span Calibration	5 kg or 5 lb to 100% capacity	
Interface	Bidirectional RS232C	
Overall Dimensions (W x D x H)	8.2 x 2.8 x 6.5 in. / 210 x 71 x 168 mm	8.3 x 2.8 x 5.8 in. / 212 x 71 x 149 mm
Net Weight (lb/kg)	3.6 lb / 1.6 kg	6.6 lb / 2.9 kg
Shipping Dimensions	10.7 x 9.3 x 6.9 in. / 272 x 235 x 175 mm	10.7 x 9.2 x 7.2 in. / 272 x 234 x 182 mm
Shipping Weight (lb/kg)	5.7 lb / 2.6 kg	8.8 lb / 4.0 kg
Operating Temperature Range	14°F to 104°F / -10°C to 40°C Maximum relative humidity 80 % for temperatures up to 31°C / 88°F, decreasing linearly to 50 % relative humidity at 40°C / 104°F, non condensing	
Power	9 VDC, 0.5A, AC adapter or internal rechargeable, sealed lead-acid battery (100-hour typical operation with full charge)	100-240 VAC / 50-60 Hz, internal power supply

Outline Dimensions

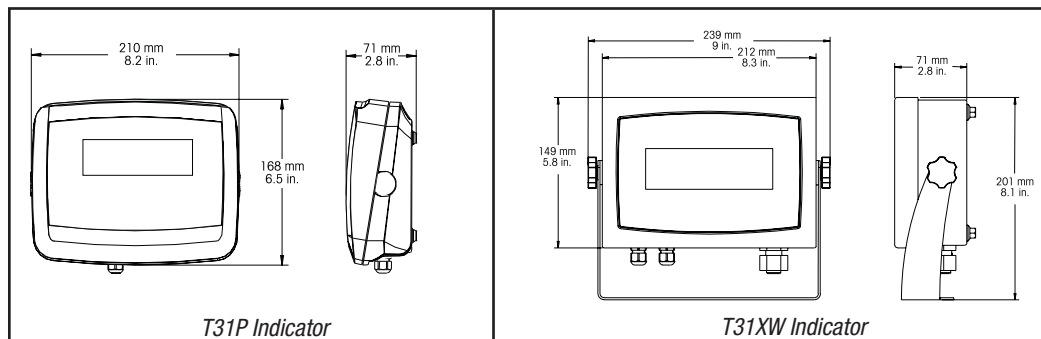

T31P/T31XW Software Features

Software included for parts counting mode with selectable sample sizes, selectable span calibration points, averaging level, auto-zero tracking, battery saving auto-off, geographical gravity calibration adjustment and software menu lockouts.

Features

T31P: ABS plastic housing with internal rib reinforcements, reversible rear cover, backlit LCD weight display, tactile mechanical keys, built-in bidirectional RS232C with manual/continuous/interval printing, hardware configuration lockout switch, internal lead-acid rechargeable battery and AC adapter.

T31XW: Stainless steel water resistant IP66/NEMA4X housing, integral faceplate supports for easy servicing, backlit LCD weight display, tactile membrane keys, built-in bidirectional RS232C with manual/continuous/ interval printing, hardware configuration lockout switch, universal switching power supply.

Accessories

Column mount kits, wall mount kits, interface cables, printer. Contact OHAUS for more information.

Approvals

- Safety and EMC: EN60950, EN61326, FCC, CE, cUL_{US}
- Quality: OHAUS quality management system registered to ISO 9001:2000

Ohaus Corporation
* 19A Chapin Road
P.O. Box 2033
Pine Brook, NJ 07058 USA

Tel: 800.672.7722
973.377.9000
Fax: 973.944.7177

www.ohaus.com

With offices throughout Europe,
Asia, and Latin America

* ISO 9001:2000
Registered Quality Management System

80774285_A © Copyright Ohaus Corporation

