

E1070 INDICATOR



Standard Fieldbus Interfaces

- ▷ Ethernet 10/100
 - ModBus/TCP
 - TCP/IP
 - SMTP
 - DHCP
 - Ethernet/IP™
- ▷ PROFIBUS® DP
- ▷ DeviceNet™

THE evolution SERIES

The Power of Intelligence

Just one instrument with so much capacity for work

One way to gauge the value of a weighing instrument is to measure its ability to grow and adapt to new processes. The Model 1070 switches easily from job to job. Easy-to-use, this indicator/controller applies to general weighing applications adding the capability of process control interface and data management.

Control and Communication

Uncomplicated, the Model E1070 provides process control and data management to most standard and custom-configured weighing platforms using bench and floor scales. Offering the advantage of the built-in interfaces—Ethernet 10/100, PROFIBUS® and DeviceNet™—the indicator/controller is ideally suited for sharing data in tank weighing and truck scale applications.

In addition to network interfaces, the Model E1070 connects to printers, remote displays, computers and SensorComm™. SensorComm is the Avery Weigh-Tronix micro-processor-based digital junction box. It gives unparalleled flexibility to truck scales and batching Weigh Bar® systems.

The bright LED display with 0.8" digits allows the operator to view weights with a quick glance.



Model E1070 provides control information to PLC and transmits data via built-in Ethernet, DeviceNet, PROFIBUS DP.

Specialized Applications

Checkweighing: The display includes a multi-segment fan graph for fast evaluation. The operator can instantly verify that products are within the target range or above or below acceptable tolerance.

Counting routines: The Model E1070 can display the number of pieces or average piece weight, along with gross, net or tare weights.

Peak weight: If a maximum weight reading is required, the Model E1070 can capture and display the peak measurement of stable weights.

Process control: The indicator is equipped with three setpoint controls to interface with relays for automated mixing or blending operations.

Added performance features

The Model E1070 can serve as a remote display in applications where weights must be read in two locations.

Weight information can be transmitted to peripheral printers and/or computers through the indicator's dual communication ports. The format of the information may be customized and can include time and date.

A NEMA 6/4X rated enclosure ensures reliable, continuous operation in dusty or wet environments.

An optional remote foot control is available for improved efficiency in common "lift and weigh" applications. It gives the operator hands-free control of common scale functions: Zero, Print, Tare, Units or F1.

Avery Weigh-Tronix

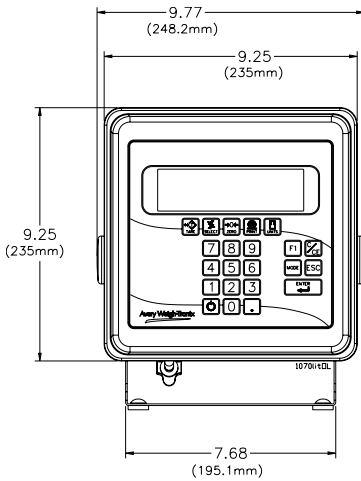

Front View and Dimensions

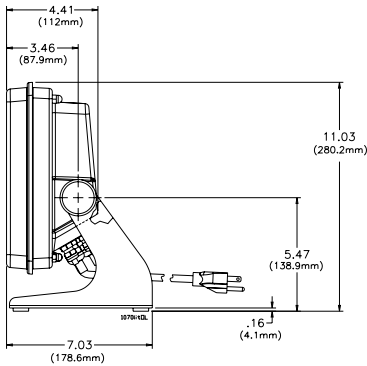

Side View and Dimensions



AUTHORIZED DISTRIBUTORS

Avery Weigh-Tronix distributors are complete support centers, providing needs assessment, technical information, product sales and service. Call or visit www.wtxweb.com for your nearest Avery Weigh-Tronix distributor.

Power requirements

- 85-265 Volts AC @ 0.3Amp maximum
- 50/60 Hz

Excitation

- +/- 5 volts DC
- Supports up to eight 350-ohm weight sensors

Analog signal input range

- +/-60 mV

Analog signal sensitivity

- 0.2 μ V/V/divisions minimum
- 1.0 μ V/V/divisions recommended

Calibration

- 2 to 5 points stored

Operational keys

- Twenty-two keys:** Tare, Select, Zero, Print, Units, F1, Clear, Mode, Escape, Enter, On/Off, Decimal, 0-9 numeric

Operational annunciators

- Center of Zero, Motion, Gross, Net, Tare,
- Under/Target//Over
- Units of measure (LB, KG)
- Print, OP1, OP2, OP3, Pt Tare

Display

- Six-digit, seven-segment, 0.8-inch high, LED

Display rate

- Selectable (1, 2, 5, 10)

Analog to digital conversion rate

- 100 times per second

Unit of measure

- Pounds, kilograms, custom

Capacity selections

- 999,999 with decimal located from zero to five places

Incremental selections

- Multiples and sub-multiples of 1, 2, 5

Programmable selections

- Zero range, motion detection, automatic zero tracking, five-point linearization.

Time and date/RAM

- Battery backed up real time clock and RAM standard

Internal resolution

- 53,687,100 counts per mV/V per second

Harmonizer™ digital filtering

- Fully programmable to ignore noise and vibration

Standard inputs

- Three logic level inputs for:** Zero, Print, Tare, Units and F1

Standard outputs

- 10/100 Ethernet (Modbus/TCP, TCP/IP, SMTP, DHCP, Ethernet/IP)
- PROFIBUS DP
- DeviceNet
- Three cutoff outputs
- Two serial ports
 - RS-232/422/485 (SensorComm) selectable
 - RS232 or 20mA current loop

Serial Command Inputs/Outputs

- Programmable serial response to ASCII character input
- SMA protocol, Broadcast, Enquire, RD-4100, E-Series remote display

Self diagnostics

- Display, keys, inputs, outputs, serial port, A to D converter

Circuitry protection

- RFI, EMI, and ESD protection

Options

- Analog output/Pulse input
- ControlNet™
- Remote I/O™
- TIU3
- Washdown remote foot control

Operating applications

- General weighing, Accumulation, Batching, Counting, Checkweighing, Peak measurement, Remote display

Operating temperature

- 14 to 104° F (-10 to 40° C) NTEP
- 40 to 140° F (-40 to 60° C) non-legal
- Up to 95% noncondensing humidity

Enclosure

- Stainless steel NEMA 6/4X

Dimensions

- 9.25" W x 9.25" H x 4.5" D (without mounting bracket)
- 9.75" W x 11" H x 7" D (with mounting bracket)

Weight

- 8.5 lb, 4 kg

Agencies

- NTEP CC#04-031
 - Class III/IIIL:10,000 divisions
- OIML certificate number R76/1992-GB1-E410
- Canadian Weights and Measures pending
- UL/CUL
- CE marked

Avery Weigh-Tronix

Fairmont, Minnesota U.S.A.

Pointe Claire, Quebec Canada

USA Toll-free: 800-368-2039

CAN Toll-free: 800-561-9461

USA Phone: 507-238-4461

CAN Phone: 514-695-0380

www.wtxweb.com

www.weigh-tronix.ca



Specifications are subject to change in accordance with technical modification.
4/06 E1070_L.qxd (C&D) PN09954-0015B
ODVA™, Ethernet/IP™ and DeviceNet™ are trademarks of ODVA.
PROFIBUS® is a registered trademark of PROFIBUS International.